

Molecular Geometry and Hybrid Orbitals

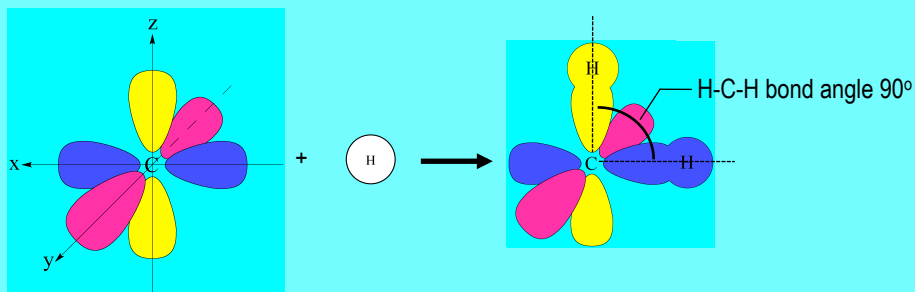

Molecular Geometry

Why Should I Care About Molecular Geometry?

Molecular geometry (shape) influences...

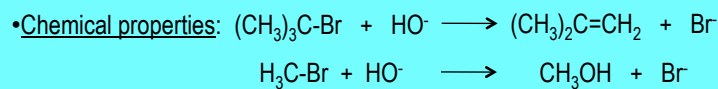
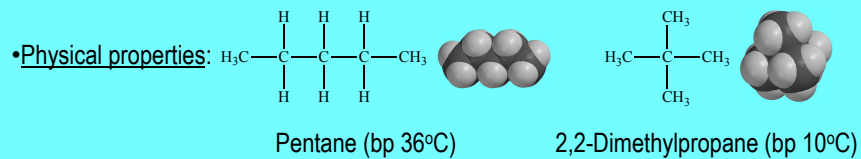

• Biological properties: Enzyme specificity

Molecular Geometry

How Do We Determine Molecular Shape?

- Empirically (spectroscopy, etc)
- Predict via theory

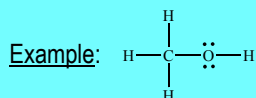

CH₃OH Lewis structure implies planarity

But other geometries can be conceived

So what is the real structure of this molecule?

- Bonds vibrating, bending, etc.
- By 'geometry' we usually mean 'most common' geometry
- Most common geometry = geometry with lowest energy

What Controls Molecular Geometry?

Most common geometry = geometry with lowest energy

Lowest energy results from...

...minimizing electron repulsion (nonbonded interactions; van der Waals repulsions)

...resonance, conjugation, and aromaticity

How does the molecule minimize electron repulsion?

- Moving electron clouds (electron groups) away from each other
- Electron groups = Atoms







Groups of atoms

Lone pairs

- Valence Shell Electron Pair Repulsion theory (VSEPR)

Molecular Geometry Survey

Best geometry = largest distance between electron groups

Composition	Geometries		Example
AB	Linear	A—B	H—H
AB ₂	Linear	B—A—B	$\ddot{\text{O}}=\text{C}=\ddot{\text{O}}$
	Bent		
AB ₃	T-shape		
	Trigonal planar		

Molecular Geometry Survey

Best geometry = largest distance between electron groups

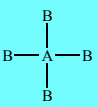
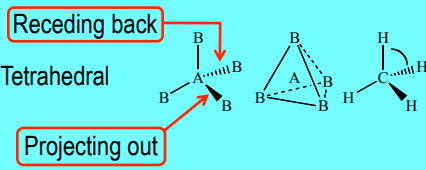
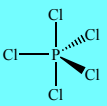
Composition	Geometries	Example
AB ₄	Square planar	
	Tetrahedral	
AB ₅	Trigonal bipyramid	

Explore and verify molecular geometry examples with molecular models

Bond Angles

Best geometry = largest distance between electron groups

Are bond angles always equal?

- Bond angles controlled by magnitude of electron group repulsions



Electron groups equal size
All H-C-H 109.5°

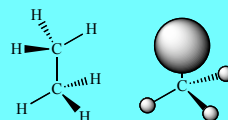

H-N-H 107°

H-C-H < 109.5°

Electron group repulsions equal

Electron group repulsions unequal

Which electron groups have greatest repulsion? (Which electron groups are largest?)

Approximate size ranking: H, F < lone pair, Cl, Br, I < all groups of atoms

Bond Angles

In general...

- Two electron groups = linear
- Three electron groups = trigonal planar or distorted trigonal planar
- Four electron groups = tetrahedron or distorted tetrahedron

Warning! Atomic geometry may also be influenced by...

...resonance (covered in Chem 30A)

...conjugation }
...aromaticity } Not a consideration in Chem 30A

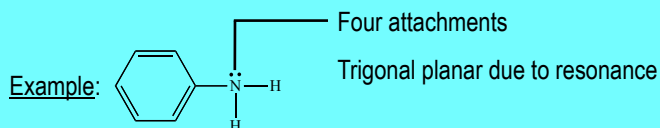

Molecular Geometry and Orbitals

Covalent bonds formed by overlap of orbitals

•Example: Two H 1s orbitals (spheres) overlap to form H-H bond

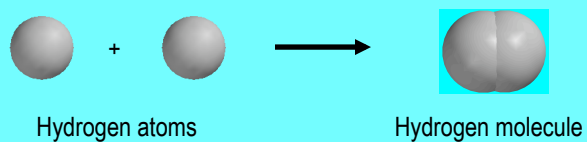

Molecular Geometry and Orbitals

What orbitals are used for organic molecules? Example: Methane (CH_4)

$\text{H} (1s) + \text{C} (2s, 2p_x, 2p_y, 2p_z) \rightarrow \text{C-H bonds}$

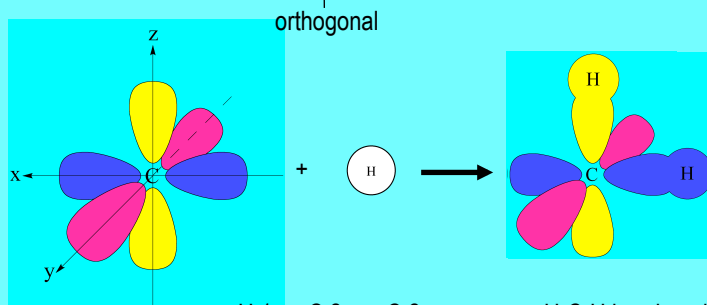

Therefore this orbital combination incorrect

Verify with your model kit

Molecular Geometry and Orbitals

Solution (Linus Pauling, 1931)

- Combine s , p_x , p_y , and p_z orbitals to form correct # of bonds with correct geometry
- Combinations = **hybrid orbitals**

Hybridization scheme for atom with four electron groups

- CH_4 geometry = tetrahedral; need four bonds and four hybrid orbitals
- Orbital conservation: four hybrid orbitals come from four atomic orbitals

• $\text{C } sp^3 + \text{H } 1s \rightarrow \text{C-H } \sigma$ bond

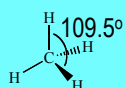
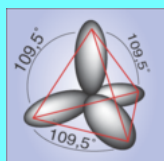

Molecular Geometry and Orbitals

Hybridization scheme for atom with three electron groups

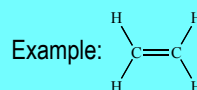

- Carbon = trigonal planar; need three bonds and three hybrid orbitals
- Three hybrid orbitals come from three atomic orbitals:

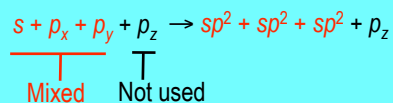

Top view without p_z

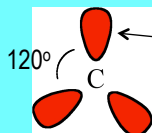

Top view with p_z

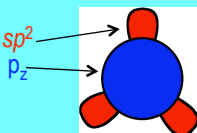

Side view

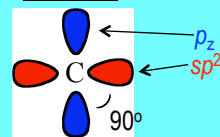

Molecular Geometry and Orbitals

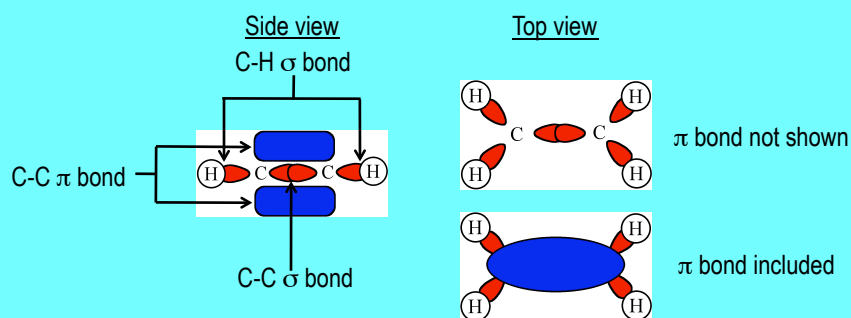
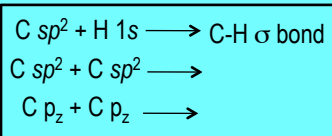
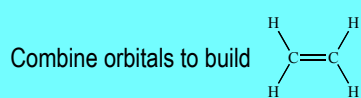

Explore and verify with molecular models

Molecular Geometry and Orbitals

Hybridization scheme for atom with two electron groups Example: $H-C\equiv C-H$

- Carbon = linear; need two bonds and two hybrid orbitals
- Two hybrid orbitals come from two atomic orbitals:

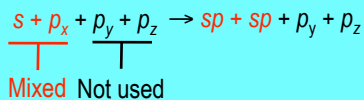

Top view without p_z

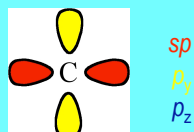

Top view with p_z

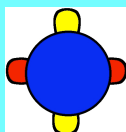

Side view without p_y

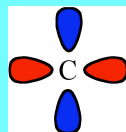

Side view with p_y

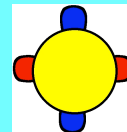

Molecular Geometry and Orbitals

Combine orbitals to build $\text{H}-\text{C}\equiv\text{C}-\text{H}$

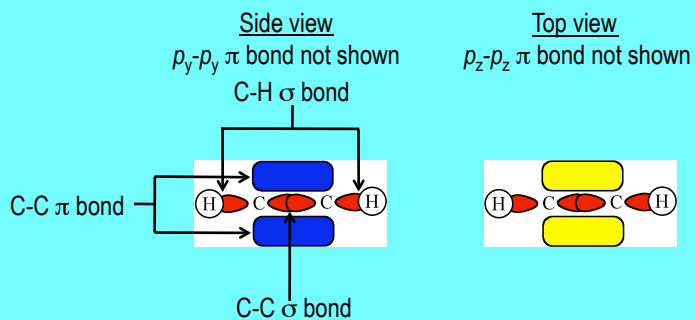
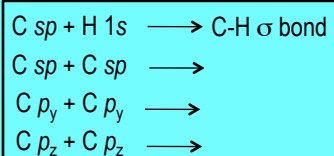

Explore and verify with molecular models

Molecular Geometry and Orbitals

A few final notes...

- Other double bonds (C=O, C=N) similar orbital arrangements to C=C
- Other triple bonds (C≡N) similar orbital arrangements to C≡C
- C, O, N almost always hybridized in organic molecules

Four electron groups
 sp^3

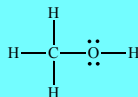

Three electron groups
 sp^2



Two electron groups
 sp

